

## Services

- Long-term charge/discharge cycles and performance studies for low temperature metal hydrides storage systems.
- Performance studies of materials for hydrogen storage in autoclave reactor up to 100 ml.
- Hydrogen and helium leak test in pressure vessels and storage systems up to 700 bar.
- Hydrostatic testing (water jacket test and direct pressurization) up to 1100 bar.
- Internal inspection with videoscope.
- Defect analysis through ultrasonic phased-array technique.
- Technical advise for the design and implantation of hydrogen storage systems and facilities.

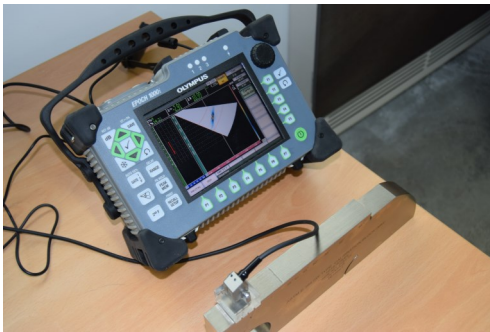

**Mr. Francisco Javier Saiz Sevilla**  
**H<sub>2</sub> Storage Laboratory Manager**  
Email: [francisco.saiz@cnh2.es](mailto:francisco.saiz@cnh2.es)

**Prolongación Fernando el Santo, s/n**  
**13500 PUERTOLLANO (Ciudad Real)**  
**SPAIN**

**Tel.: +34 926 420 682**  
**Fax: +34 926 670 507**  
**E-mail: [info@cnh2.es](mailto:info@cnh2.es)**



 CNH2es

 @cnh2\_es

 CNH2 Centro Nacional del Hidrógeno

[www.cnh2.es](http://www.cnh2.es)

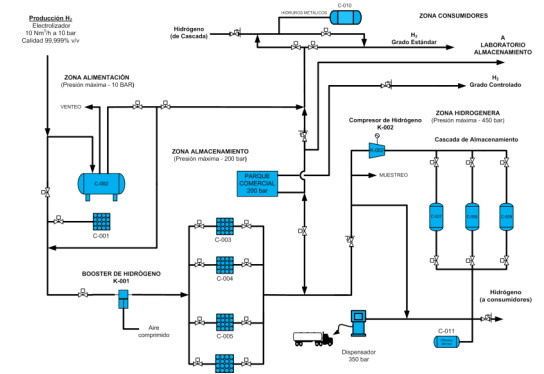

## H<sub>2</sub> STORAGE LABORATORY



GOBIERNO DE ESPAÑA

MINISTERIO DE ECONOMÍA Y COMPETITIVIDAD



UNIÓN EUROPEA  
FONDO EUROPEO DE DESARROLLO REGIONAL

"Una manera de hacer Europa"



Castilla-La Mancha



The objective is to develop hydrogen storage technologies, particularly the high pressure compressed and the chemical (hydrides) storage, with facilities and equipment to offer services and support as technical advice related with the design and implementation of hydrogen storage systems.



### Laboratory areas

- High pressure compressed hydrogen, performing tests and working with pressures above the common standards for hydrogen storage technologies.
- Hydrogen storage in chemical systems, focused on low temperature reversible metal hydrides.



### High pressure compressed hydrogen

- Test bench for hydraulic testing of components, vessels and storage systems up to 1500 bar (water jacket test and direct pressurization method).
- Portable hydraulic pump from 300 bar up to 2070 bar for field trials.
- Test bench to determine leakage rates and permeability in type IV vessels (composite gas cylinders) and systems up to 1100 bar.
- Micro gas chromatograph for hydrogen determination at ppm levels in controlled atmosphere with inert gas.
- Ultrasonic phased-array system for determination of imperfections in welds and metals for hydrogen service equipment.

### Hydrogen storage in chemical systems

- Test bench for metal hydride vessels and systems up to 10 Nm<sup>3</sup>, 100 bar pressure and 80°C. With the capability of undertake studies related with hydrogen purification or with compression stages.
- Measurement of storage process variables (flow charge/discharge times, as well as operational pressures and temperatures).
- Commercial metal hydride vessels of 1.5, 5 and 10 Nm<sup>3</sup> storage capacity.
- Circulating cryothermostats for temperature control (range -45 to 200°C).
- Exhausting system for safe working area with chemical systems and assemblies.

